



PRESS KIT 2021

SUMMARY



01 VISION

02 RANGE

03 EXCESS LAB

04 RENT AN EXCESS

06 TORQUEEDO

07 EXCESS OWNERS

08 CONTACTS

01 VISION

*"Moderation is a fatal thing.
Nothing succeeds like excess!"*
Oscar Wilde

Setting sail today is the fulfilment of other desires, new approaches. Sailors now sail in many ways. Catamarans follow this trend more than ever: a 360° sea experience.

EXCESS embodies this vision and meets the new demands of aesthetics and simplicity, reflecting an active and spontaneous lifestyle trend of city dwellers searching for escape and outdoor sports.

02 RANGE



XCS
Excess

EXCESS 11

The **Excess 11** is the only large-scale production boat on the market for this size of catamaran. She is one of the smallest cruising catamarans capable of offering so much comfort and space, not to mention the thrill of sailing.



CONFIGURE IT

SUMMARY

02 RANGE



EXCESS 12

The **Excess 12** adopts a marked chine and a pronounced deck sheer, creating unique lines. Her twin helm stations, located aft, offer a maximum of sensations and create a more seamanlike concept that brings us closer to the sea. The light and precise helm and the opening bimini are reminiscent of the pleasures of helming a monohull.



CONFIGURE IT

SUMMARY

02 RANGE



EXCESS 15

With an area of 125 m² (1,345 sq ft) and her 25-meter (82') high mast, the **Excess 15** is the largest in the new Bénéteau Group family. In addition to her large spaces, this boat has twin helm stations, located at the after end of each hull, which are designed to increase the pleasure of sailing.



CONFIGURE IT

SUMMARY

03 EXCESS LAB

MANIFESTO

The Excess Lab gives **the opportunity to join our Design Team**, to **interact with our specialists** and naval architects. The participants will discover the features they are currently working-on and will **invited to participate in the decision making process** when selecting the options we will feature on our next Excess catamarans.

The Excess Lab **also allows to post your suggestions** and to share the topics they would like our Team to investigate or develop.

"We are convinced that connecting you, sailors, with our professional team will be an enriching experience for all. It will be rich of learnings for us, no doubt. We certainly hope that it will be enriching for you too!"

DO YOU WANT MORE?

Excess Lab

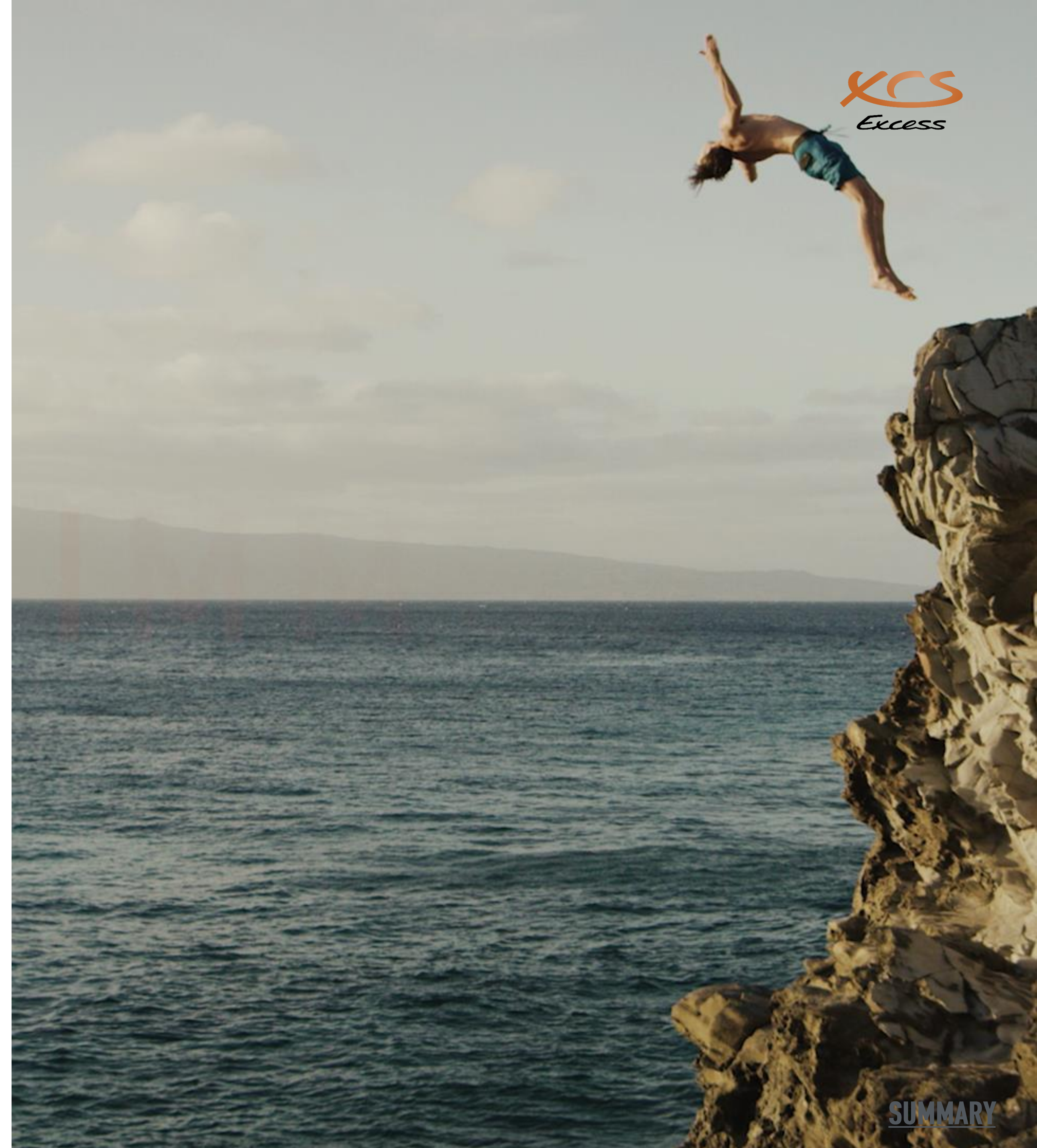

SUMMARY

03 RENT AN EXCESS

Find your dealership or see all the Excess rental offices

On this platform it is possible to get in touch with Excess charters.

Find your dealership [or see all the Excess rental offices](#)

France

Seaways Yachting **CONTACT** →
 71, avenue des Frères Roustan
 06220 Golfe Juan
 France
Available boats to rent : EXCESS 11

ATLANTIC YACHTING **CONTACT** →
 1b rue François Toullec
 56100 Lorient
 France
Available boats to rent : EXCESS 11 | EXCESS 12

Excess'if **CONTACT** →
 35 Quai de Rive neuve
 13007 Marseille
 France
Available boats to rent : EXCESS 11

Discover the list of charters, the specificities of the boats and the city of departure [here](#).

Trying an Excess has never been so easy and fun!

RENT AN EXCESS BOAT

TORQUEEDO

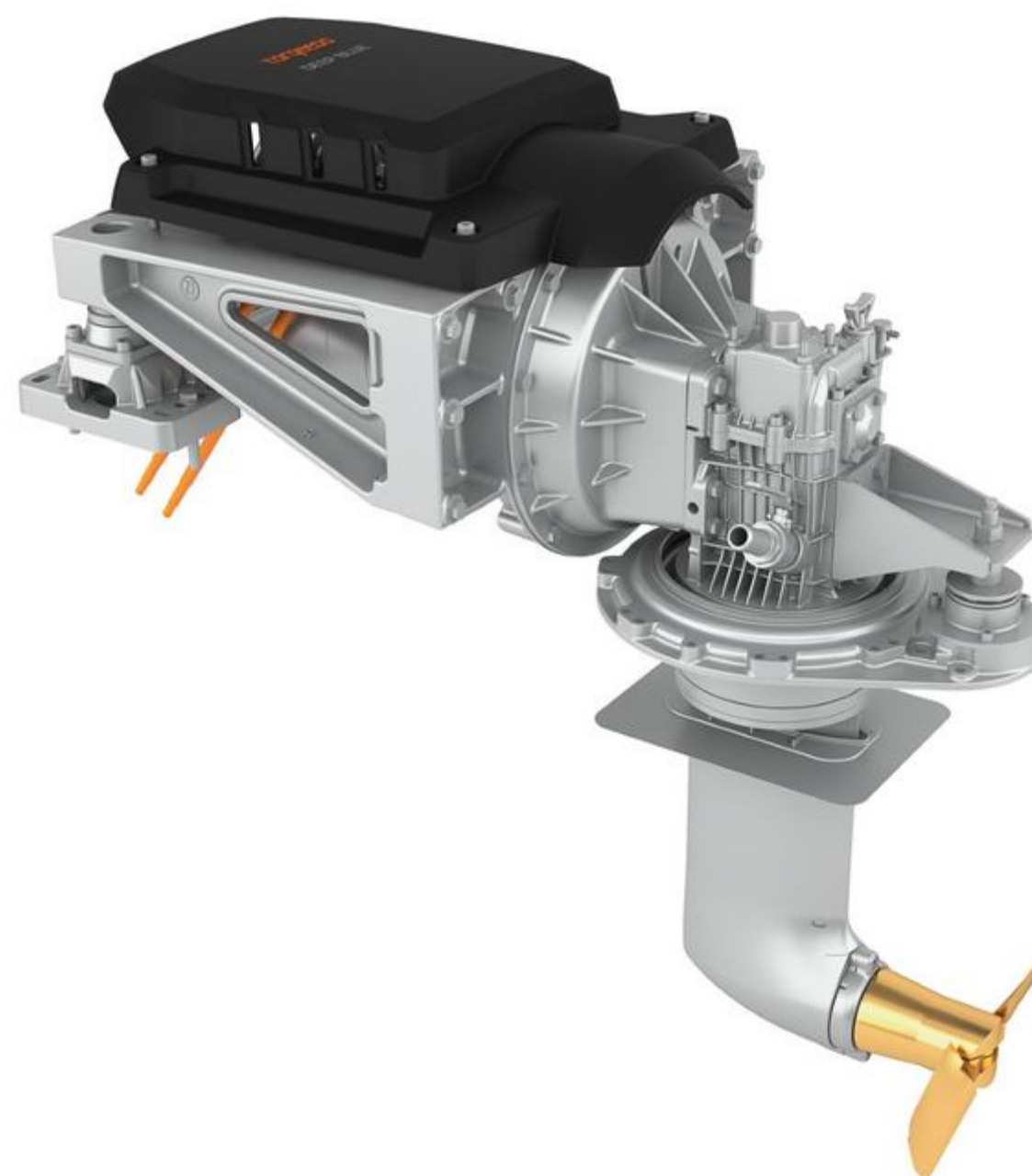

[DO YOU WANT MORE?](#)

Torqueedo

Torqueedo is the market leader for electric mobility on the water. Founded in 2005 in Starnberg, the company develops and manufactures electric and hybrid drives from 0.5 to 100 kW for commercial applications and recreational use.

06 TORQUEEDO

Excess innovates with its hybrid Excess 15 project

Excess introduces at the Cannes Yachting Festival the first hybrid Excess 15 equipped with Torqueedo's flagship Deep Blue Hybrid system. With such an innovative project managed through the "Excess Lab", Excess is taking a distinctive first step within the catamaran market towards more sustainability.

A peaceful experience

Aboard the Excess 15 with Deep Blue Hybrid, owners will enjoy all onboard luxuries without the noise and fumes of a running generator in good sailing weather.

06 EXCESS OWNERS

There are Excess catamarans sailing all over the world!

Here are some owners who sail on Excess and share their experience.

@sailingbombarda



Lizzy and Marco, thirty-something entrepreneurs, originally from Amsterdam have decided to set off for a year to travel the oceans aboard their Excess 11 christened "Bombarda".

@sy_binx

Mack Storey had a dream: to sail around the world with his family aboard their Excess 15, BINX. However, the health crisis forced them to adapt their plans, and they ended up completing their semi-circumnavigation in record time.

A SEMI-CIRCUMNAVIGATION IN UNDER 6 MONTHS!

@sailing_excess



THE NEXT MEETINGS

SEPTEMBER 2021

ST-TROPEZ
BANDOL

OCTOBER 2021

LOANO
CANET-EN-ROUSSILLON

COME AND MEET US

PRESS CONTACT

Advertising contact

Victoria Alaman
v.alaman@cnb.fr

Press contact

Laurie Viala
l.viala@cnb.fr

EXCESSS-CATAMARANS.COM



SUMMARY

The logo consists of the letters 'XCS' in a stylized, orange, sans-serif font. The 'X' is formed by two overlapping curved lines, and the 'C' and 'S' are also formed by thick, curved strokes. The logo is centered horizontally and positioned above the word 'Excess'.

XCS

Excess